



Model F30 Metallic

AIR OPERATED DOUBLE DIAPHRAGM PUMPS

Specifications

Suction & Discharge Size:	3" x 3"
Porting Location:	Center
Connection Types:	FNPT, BSPT
Air Inlet:	3/4" FNPT
Porting Location:	Center
Exhaust port:	1 FNPT, BSPT
Aluminum Shipping Weight :	116 lbs. (53kg)
Stainless Steel Shipping Weight :	194 lbs. (87kg)

Capabilities

Maximum Flow Rate:	285 gpm (1078 lpm)
Maximum Air Supply Pressure:	125 psi (8.6 bar)
Displacement Per Stroke:	0.94 gal (3.56 lit)
Minimum Air Inlet Pressure:	10 psig (0.7 bar)
Maximum Particle Size :	0.38 in (9.65 mm)
Operating temperature:	Determined by elastomers

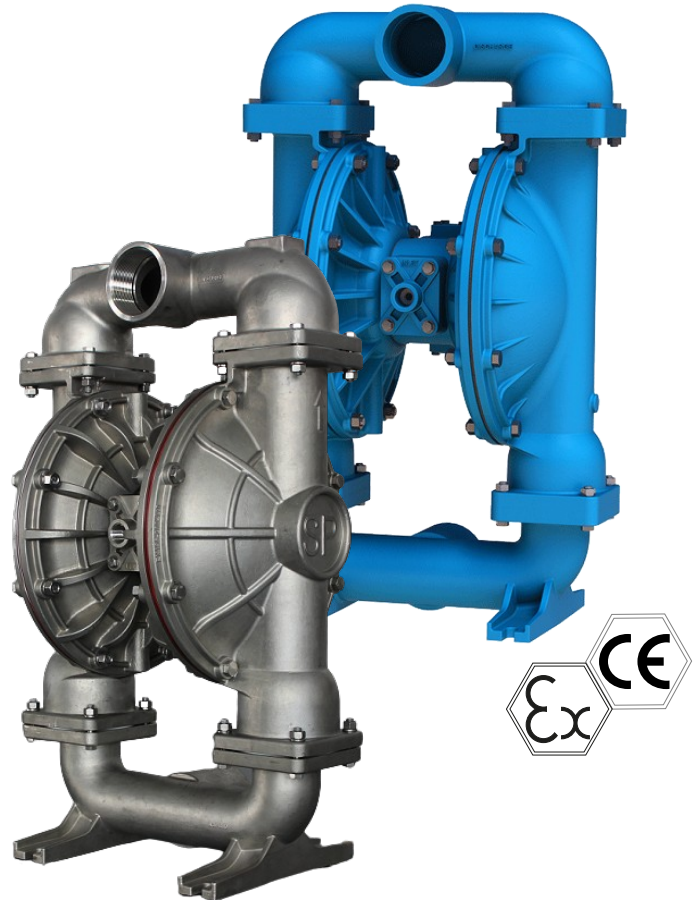

F20 Performance

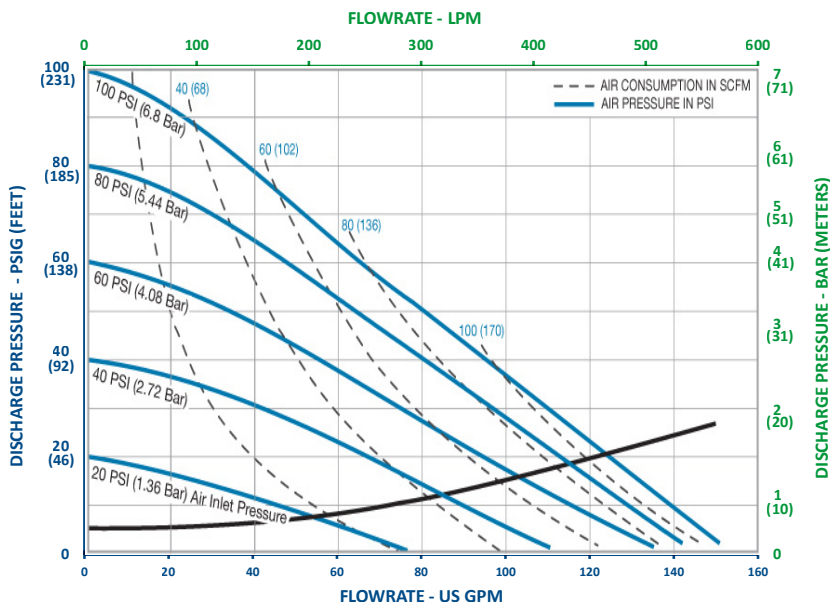

Note: Full stroke diaphragm allows performance to be equal for all elastomers.

Typical Applications

- Acids & Bases
- Plating Solutions
- Wastewater
- Paints, Inks, Solvents
- Ceramic Slip and Glaze
- Lubricants and Oils

Typical Industries

- Mining
- Paints and Coatings
- Ceramics
- Pulp and Paper
- Electroplating & Anodizing
- Wastewater
- Marine
- Chemical Manufacturing & Distribution
- OEM's

FTA Pumps

27027 Westheimer Pkwy, Katy, TX
Tel: 713 344 1226



Construction

Wetted Materials:	Aluminum
Diaphragm Materials:	Neoprene, Santoprene™, FKM, EPDM, PTFE, Buna, Hytrel®, Polyurethane
Air Valve:	GFRPP, Aluminum
Ball Materials:	Neoprene, Buna, EPDM, FKM, Santoprene™, PTFE
Seat Materials:	Aluminum, 316SS, PTFE, Hytrel, Buna, Neoprene, EPDM, FKM, Santoprene™, Polyurethane
O-ring Materials:	Neoprene, Buna, EPDM, FKM, PTFE, FEP/FKM

Santoprene™ is a registered trademark of Exxon Mobil Corp.
 Hytrel® is a registered trademark of Dupont™

THE RIGHT CHOICE

Dimensions

Maximum Height:	26.47 in (672 mm)
Maximum Width:	16.88 in (428 mm)
Maximum Depth:	11.63 in (295 mm)

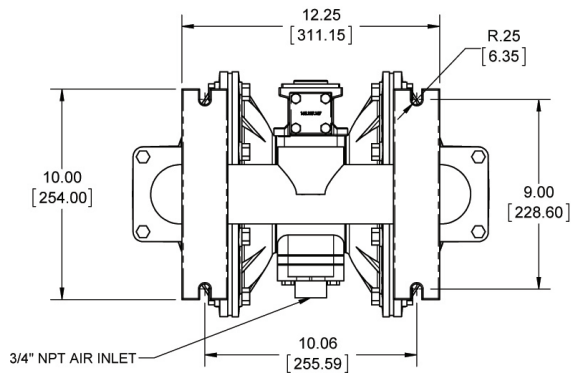
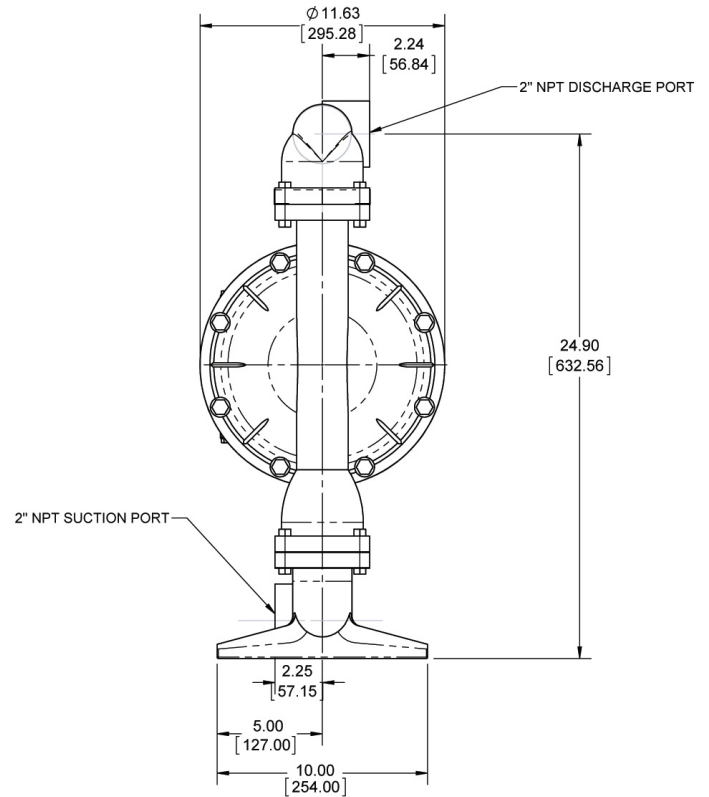
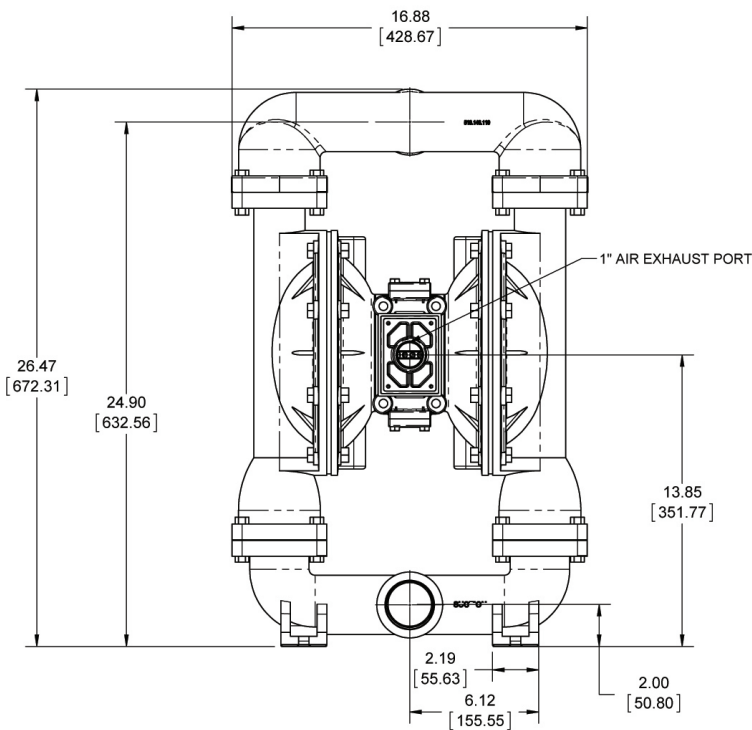

BOTTOM VIEW



FTA Pumps

27027 Westheimer Pkwy, Katy, TX
 Tel: 713 344 1226

